

# Leonardo ATC System

**Integrated friction system to guarantee a higher safety**  
*Sistema di frizione integrato per garantire una maggior sicurezza*



**Completely integrated with the machine tool with M code**

*Completamente integrato alla macchina utensile tramite codici M*



**Adjustable speed up to 80.000RPM**

*Velocità fino a 80.000 RPM regolabile*



**Can be installed on each machine**

*Installabile su ogni tipo di macchina*



**Ideal for continuous machining without thermal growth**

*Adatto a lavorazioni in continuo senza dilatazione termica*



**Stop Block with electric contacts completely protected from chips**  
**10 mt cable included**

*Tassello con contatti elettrici completamente protetti da trucioli- Inclusi 10 mt di cavo*



**Nakanishi controller unit with adjustable RPM and sensor to stop machine spindle**

*Centralina Nakanishi con regolazione di giri e sensore per arresto mandrino*

# Leonardo ATC 30

# Leonardo ATC 40

**Max power**  
*Potenza massima*  
**130 Watt**



**Max power**  
*Potenza massima*  
**350 Watt**

**Up to**  
*Velocità fino a*  
**80.000 rpm**



**Up to**  
*Velocità fino a*  
**60.000 rpm**

**Collet up to**  
*Pinza fino a*  
**4 mm**



**Collet up to**  
*Pinza fino a*  
**6 mm**

**Weight**  
*Peso*  
**3 kg**



**Weight**  
*Peso*  
**4,8 kg**

**Run out**  
*Precisione*  
**1 μ**

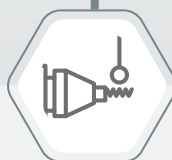

**Run out**  
*Precisione*  
**1 μ**

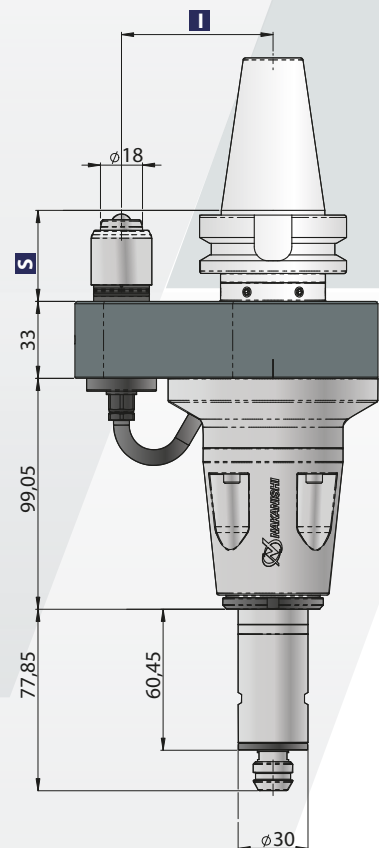
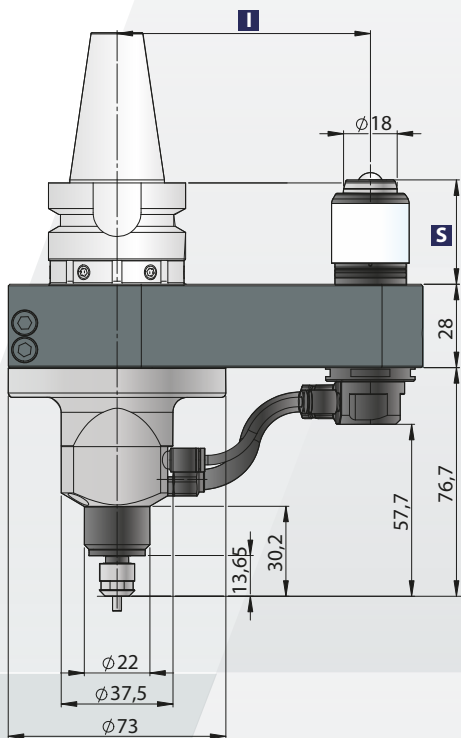

## Mounting Scheme *Schema di montaggio*

